

**PRESSURE REDUCING VALVE  
DIRECT ACTING  
PRV 25/2 S – Forged steel body**

**DESCRIPTION**

The ADCA PRV25/2S series direct acting pressure reducing valves are designed for use on steam, compressed air and other gases.

They are suitable for reducing steam pressure at the point of use on laundry machines, dyeing, food industries, sterilizers, etc.

Connections are female screwed or flanged.

**MAIN FEATURES**

Compact design.

Bellows specially designed for high durability.

Built-in strainer.

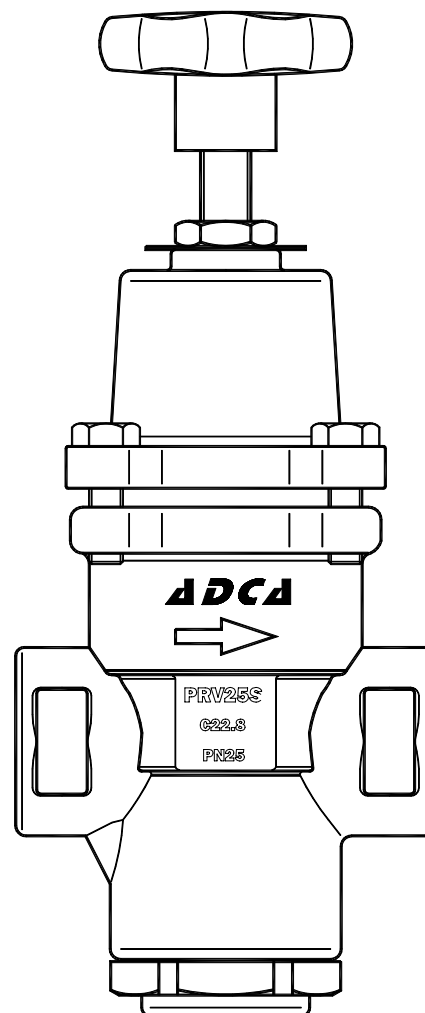

**OPTIONS:** Regulating screw with top cap.

**USE:** Saturated steam, compressed air and other gases compatible with the construction.

**AVAILABLE MODELS:**  
PRV25/2S – metal to metal seating  
PRV25/2SG – soft valve  
PRW25/2S – soft valve balanced

**RECOMMENDED APPLICATIONS :**  
PRV25/2S – steam and compressed air  
PRV25/2SG – steam and compressed air where tight off is required  
PRW25/2S – water, compressed air

**SIZES:** 1/2", 3/4", 1" ; DN15, DN20 and DN25.

**CONNECTIONS:** Female screwed ISO7/1Rp(BS 21) .  
Flanged EN 1092-1 PN40 or ANSI.

**INSTALLATION:** Horizontal installation.  
An "Y" strainer should be provided upstream the valve.  
See IMI, installation and maintenance instructions.

CE MARKING (PED - European Directive 97/23/EC)	
PN 25	Category
DN 15 to 25	SEP - art. 3, paragraph3

LIMITING CONDITIONS			
	PRV25/2S	PRV25/2SG	PRW25/2S
Body design conditions	PN25	PN25	PN25
Max.upstream pressure	17 bar	17 bar	14 bar
Max.downstream pressure	8,6 bar	8,6 bar	8,6 bar
Min.downstream pressure	0,14 bar	0,14 bar	0,35 bar
Max.design temperature	210°C	180°C	75°C
Max.cold hydraulic test	38 bar	38 bar	38 bar
Max.reducing ratio	10:1	10:1	10:1

CAPACITIES (See selection table)			
Valve Size	15	20	25
KVs	1,7	2,6	3,1

PRESSURE RANGES				
Spring colour	Blue *	Yellow **	Green	Red
Red.Press. bar	0,35 - 1,7	0,14 - 1,7	1,4 - 4,0	3,5 - 8,6

\*Applicable only on the PRW ; \*\* Appl.only on the PRV  
Where control spring ranges overlap,always use the lower range.

DIMENSIONS (mm)-Screwed						EN1092-1 Flanges		
SIZE DN	A	B	C	F	WGT. Kgs	D	E	WGT. Kgs
1/2"	90	65	175	74	2,7	150	47,5	4,2
3/4"	90	65	175	74	2,7	150	52,5	4,8
1"	100	65	175	74	3	160	57,5	5,6

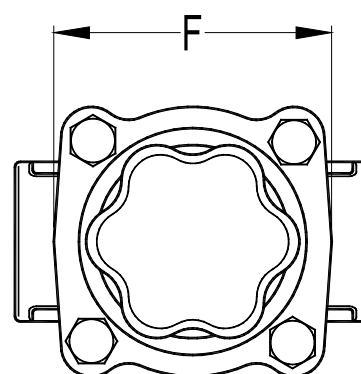
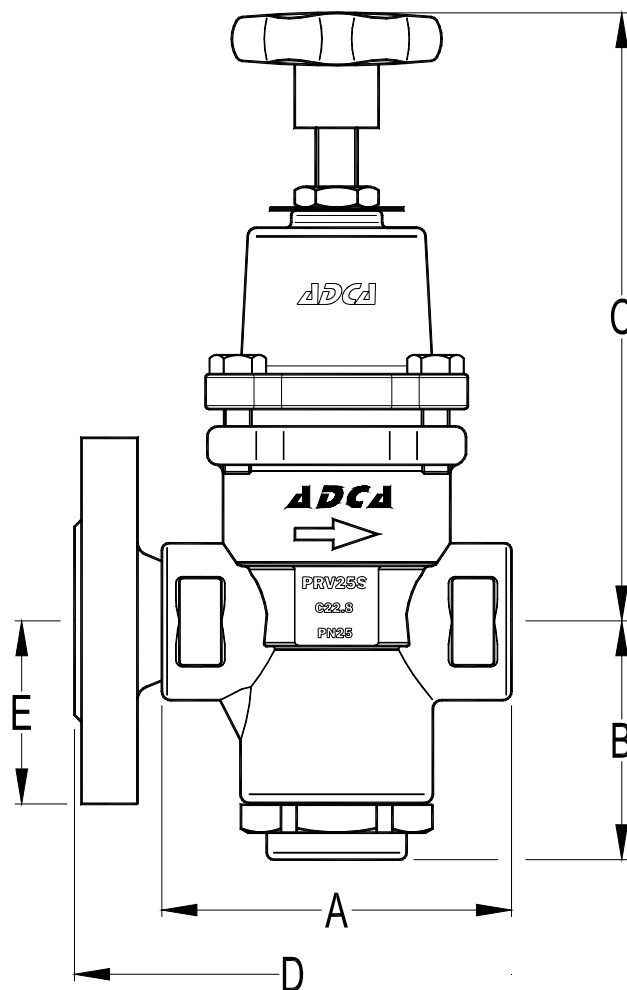

MATERIALS		
POS.	DESIGNATION	MATERIAL
1	VALVE BODY	P250GH / 1.0460
2	COVER	GJS400-15 / 0.7040
3	SEAT	AISI 316 / 1.4401
4	-	-
5	*VALVE	HARDENED ST. STEEL
5.1	*O-RING	NBR
5.2	*VALVE HEAD	NBR
5.3	*VALVE HEAD	PTFE/GRAPHITE
6	*VALVE RETURN SPRING	AISI 302 / 1.4300
7	*STRAINER SCREEN	AISI 304 / 1.4301
8	PUSHROD	AISI 316 / 1.4401
9	BOTTOM CAP	A105 / 1.0432
10	*CAP GASKET	ST.ST./ GRAPHITE
11	COVER BOLTS	STEEL 8.8
12	-	-
12.1	*GUIDE BUSH	PTFE/GRAPHITE
13	*STOP RING	AISI 304 / 1.4301
14	*BELLOWS	AISI 316 TI / 1.4571
15	*BELLOWS GASKET	ST.ST./ GRAPHITE
16	*ADJUSTMENT SPRING	STEEL
17	TOP SPRING PLATE	BRASS
18	ADJUSTMENT SCREW	AISI 304 / 1.4301
19	LOCKNUT	AISI 304 / 1.4301
20	HANDWHEEL	PLASTIC
21	SPRING IDENT.PLATE	ALUMINIUM

\* Available spare parts.

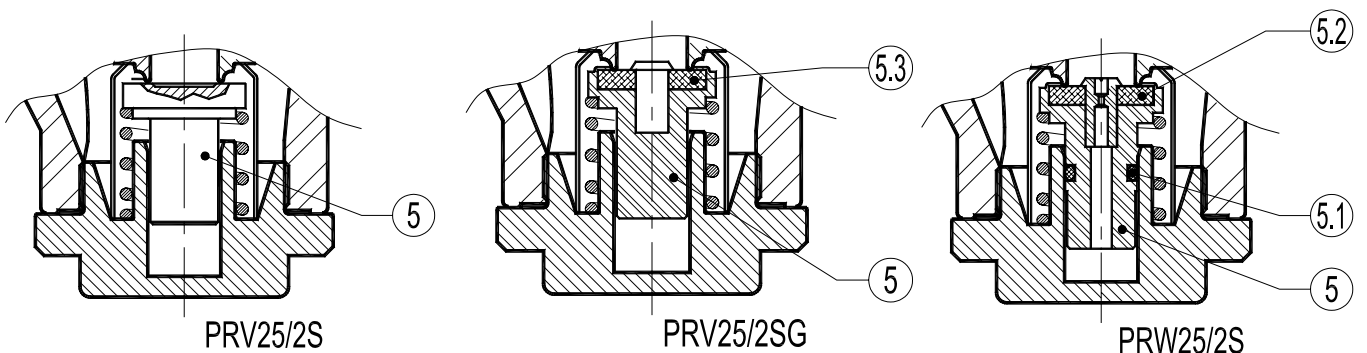



STEAM EQUIPMENT

**STEAM CAPACITY TABLE**  
(Kg/h)

INLET bar	OUTLET bar	SAT. STEAM		
		DN15	DN20	DN25
2	0,2	33	53	64
	1,2	57	87	104
	1,6	38	59	71
3	0,3	45	70	83
	1,2	76	116	138
	2,2	61	93	111
	2,6	46	70	83
4	0,4	56	87	104
	1	66	102	121
	2,5	95	145	173
	3,5	57	87	104
5	0,5	68	105	125
	2	91	139	166
	3	114	174	208
	4	85	130	155
6	0,6	79	122	145
	2	106	162	194
	3	133	203	243
	4	120	184	219
7	0,7	91	139	167
	2	121	185	222
	3,5	152	232	277
	5	132	201	240
8	0,8	102	157	187
	2	137	210	250
	3,5	171	262	312
	5	161	247	294
9	0,9	114	174	208
	2,5	133	203	242
	4	152	233	277
	5	190	291	347
10	7	152	232	277
	1	125	192	228
	3	146	224	266
	4	167	256	305
11	6	209	320	381
	8	161	247	294
	1,1	136	210	249
	3	182	280	333
12	6	228	350	416
	8	198	302	360
	8,6	182	279	331
	1,2	148	227	270
13	3	197	302	360
	6	247	378	451
	8	228	349	416
	8,6	217	332	396
15	1,3	159	244	291
	4	186	284	340
	6	212	325	388
	7	266	407	486
17	8,6	246	378	451
	1,5	182	259	321
	4	212	302	374
	6	243	345	427
17	8	304	433	536
	8,6	298	426	512
	1,7	205	279	333
	4	238	325	386
17	6	273	372	441
	8	342	465	555
	8,6	339	449	541

**COMPRESSED AIR CAPACITY TABLE**  
( Nm<sup>3</sup>/h-0°C-1,013bar )

INLET bar	OUTLET bar	COMPRESSED AIR		
		DN15	DN20	DN25
2	0,2	45	72	86
	1,2	77	117	140
	1,6	51	80	96
3	0,3	61	95	112
	1,2	103	157	186
	2,2	82	126	150
	2,6	62	95	112
4	0,4	76	117	140
	1	89	138	163
	2,5	128	196	234
	3,5	77	117	140
5	0,5	92	142	169
	2	123	188	224
	3	154	235	281
	4	115	176	209
6	0,6	107	165	196
	2	143	219	262
	3	180	274	328
	4	162	248	296
7	0,7	123	188	225
	2	163	250	300
	3,5	205	313	374
	5	178	271	324
8	0,8	138	212	252
	2	185	284	338
	3,5	231	354	421
	5	217	333	397
9	6	192	293	350
	0,9	154	235	281
	2,5	180	274	327
	4	205	315	374
10	5	257	393	468
	7	205	313	374
	1	169	259	308
	3	197	302	359
11	4	225	346	412
	6	282	432	514
	8	217	333	397
	8,6	217	333	397
12	1,1	184	284	336
	3	246	378	450
	6	308	473	562
	8	267	408	486
13	8,6	246	377	447
	1,2	200	306	365
	3	266	408	486
	6	333	510	609
15	8	308	471	562
	8,6	293	448	535
	1,3	215	329	393
	4	251	383	459
17	6	286	439	524
	7	359	549	656
	8,6	332	510	609
	1,5	246	350	433
17	4	286	408	505
	6	328	466	576
	8	410	585	724
	8,6	402	575	691
17	1,7	277	377	450
	4	321	439	521
	6	369	502	595
	8	462	628	749
17	8,6	458	606	730

**WATER CAPACITY TABLE**  
(m<sup>3</sup>/h)

D.P. bar	WATER		
	DN15	DN20	DN25
1,5	2,1	3,18	3,8
2	2,4	3,67	4,38
3	2,95	4,5	5,37
4	3,4	5,2	6,2
5	3,8	5,8	6,93
6	4,16	6,36	7,6
8	4,8	7,35	8,75
12	5,8	9	10,7